

April 27, 2015

Randall L. Sawyer
Hazardous Materials Programs Director
Contra Costa Health Services
4585 Pacheco Boulevard, Suite 100
Martinez, CA 94553

30 Day Report for the Level II Incident at The Dow Chemical Company facility in Pittsburg, CA

On March 27, 2015 at 2:50 AM, The Dow Chemical Company facility located in Pittsburg, CA had Level II incident at the Dowicil Plant. The plant had a visible plume that: 1) could be seen from off site and 2) had the potential to drift off the Dow property. At that time, the wind speed was essentially zero and the material in the plume traveled 300 yards downwind and remained on the Dow property. It is estimated that about 2,200 pounds of methylene chloride vaporized and dispersed with the air. Downwind 3d party monitoring did not detect any chemicals leaving the Dow property.

Incident Summary:

Material released: 4,700 pounds of material was released from a Dowicil reactor/dryer. An estimated 2,200 pounds of the release was methylene chloride, a solvent that vaporized and dispersed in the air. 2,500 pounds are Dowicil solids and related Dowicil decomposition products. The solids traveled 300 yards down wind with the majority of the material dropping out in the first 100 yards. No material left the Dow property and 3d party monitoring detected no chemicals downwind.

The release occurred because the Dowicil process had a decomposition reaction that led to a rapid pressure increase in the reactor/dryer vessel. This decomposition reaction was so rapid that the plant control instrumentation neither detected a pressure increase nor a temperature increase prior to the onset of the decomposition. In less than 90 seconds, the reactor dryer went from 30 psig to over 100 psig. In the same short time, the reactor temperature went from 65 C to over 100 C.

The reactor is designed with several safety pressure relief devices. All of these safety pressure relief devices activated, as designed. A 6" diameter rupture disk burst at 65 psi and the two 24" diameter rupture disks activated at 100 psi. The release incidental to these safety pressure relief devices' normal, planned activation was the visible plume.

The cause for the decomposition reaction is that both: 1) the Dowicil product dried quicker than expected and 2) the dried product was held at an elevated temperature meant for product that is not dried. The reason the product dried sooner than expected because a plug in the reflux line prevented the normal refluxing of solvent (methylene chloride) back to the reactor / dryer. Due to the plugged line, the solvent was not recycled back to the reactor/dryer. With the loss of solvent recycle, the product dried sooner than anticipated. There were also pressure control problems associated with the high solvent flow to the vent recovery system. This prevented the process from terminating the solvent

boil step and moving to the drying step where a vacuum is used, instead of heat to remove the last part of the solvent from the Dowicil product.

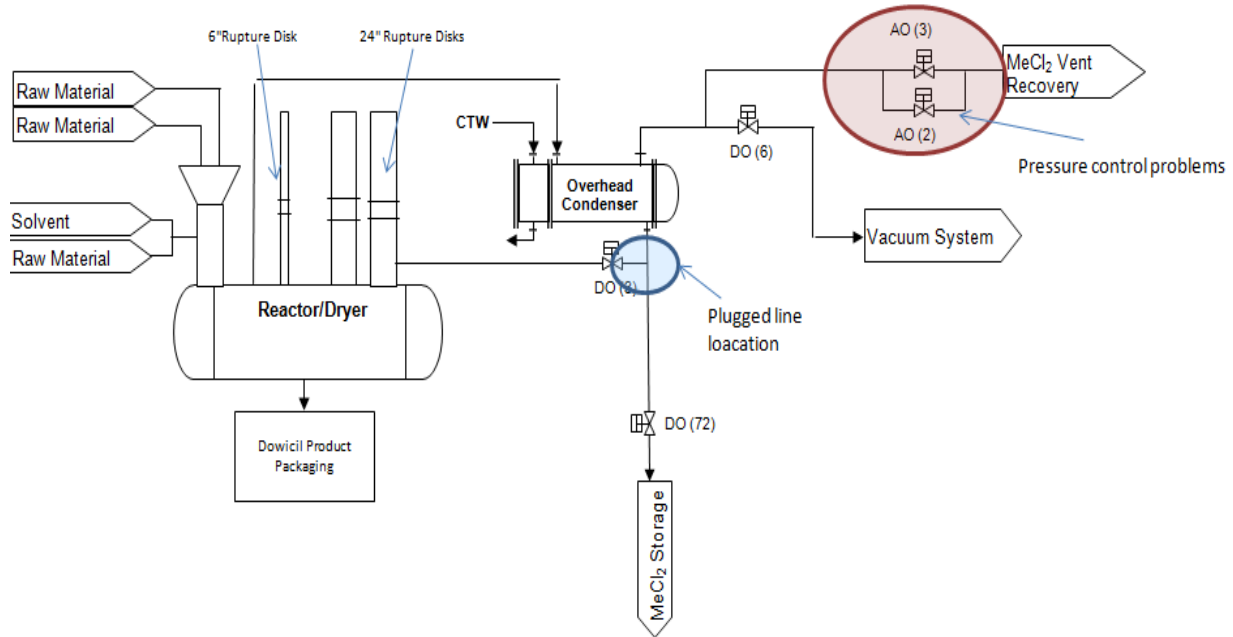

Root Causes:

Reflux line plugged, this plugging went unresolved and the consequence of loss of more solvent than usual in the react step was not understood.

Manual control was taken on the vent line pressure control loop. There was less than adequate understanding on the impact manual control has on the process step termination.

Corrective Actions:

All the following corrective actions will be completed and verified as completed before the Dowicil Plant is restarted. The anticipated plant restart date is the middle of June 2015.

Implement a means to prevent plugging or add instrumentation to identify a no flow condition in the H-210/D-201 seal leg. MOC and train operations on the changes. Estimated completion date is June 15, 2015.

Develop a process control strategy document (PCSD) for the vent header pressure control associated with the Post React Step and the Solvent Pool Boil step. Estimated completion date is June 15, 2015.

Implement process control code consistent with the process control strategy document (PCSD) for the vent header pressure control associated with the Post React Step and the Solvent Pool Boil step. Estimated completion date is June 15, 2015.

Update all associated operating discipline for the vent header pressure control associated with the Post React Step and the Solvent Pool Boil Step. Estimated completion date is June 15, 2015.

Investigation Team:

The incident investigation started the same day as the incident with the collection of process operating conditions, interviewing the operations staff and physical examination of the processing plant.

The investigation team had over 20 active participants and included the following individuals or groups: 1) A neutral facilitator from West Virginia (site leader) with extensive experience in the Apollo Root Cause Methodology 2) Process safety experts from on site and off site, including a regional process safety expert from Canada and a process safety expert from the Dowicil business, 3) Reactive chemical experts from Midland, Michigan, 5) Business technical expert familiar with Dowicil chemistry, 6) Plant operations personnel including the facility operator, the facility technical advisor, the run plant engineer and the operations leader.